

# Anchor Winch Wiring Diagram A

RE: 01072016C

## Viper S SERIES MICRO/RAPID/GRAVITY FEED DRUM WINCH

**WARNING:** Remember never to connect your battery leads until your installation is complete!

**PLEASE NOTE:** Pull your wiring loom through your boat first to calculate the position of your winch accessories before cutting any holes.

100 Amp Circuit Breaker

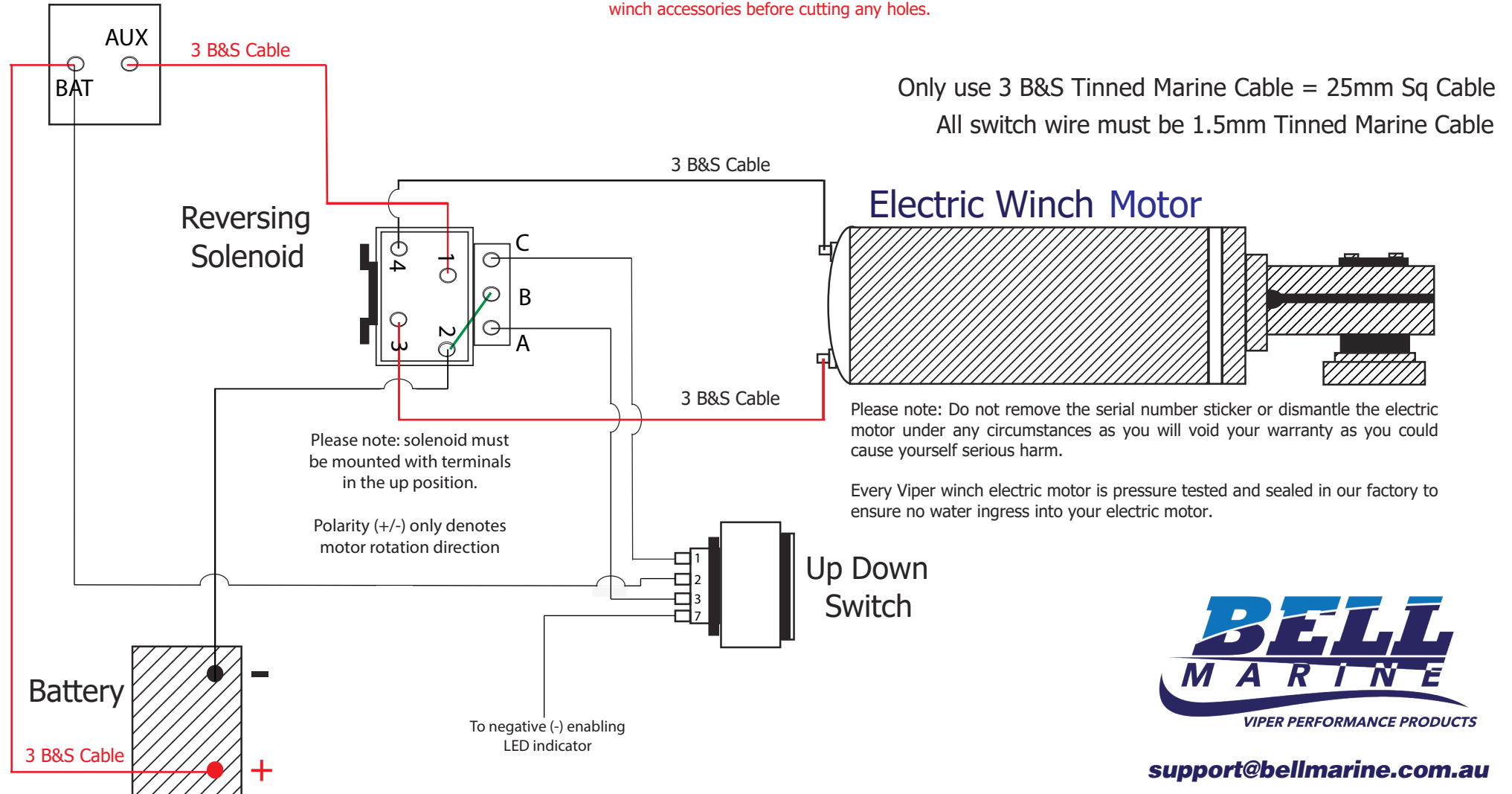

**BELL**  
MARINE  
VIPER PERFORMANCE PRODUCTS

[support@bellmarine.com.au](mailto:support@bellmarine.com.au)